

10

9

8

7

6

5

4

3

2

1

H
G
F
E
D
C
B
A

NOTICE TO CONTRACTOR AND ERECTOR
BACK CHARGES FOR CORRECTIVE WORK OR REPLACEMENT MATERIALS WILL NOT BE ACCEPTED UNLESS AUTHORIZED BY DRAWINGSINK, LLC BEFORE SUCH COSTS ARE INCURRED.
DO NOT SCALE DRAWING.

PRINT RECORD FOR APPROVAL

DATE APPROVED

FILE & FIELD

DRAWINGSINK, LLC
BOX 891
WHITE HOUSE, TENNESSEE 37188
615.512.5110
EMAIL: dwayne@drawingsink.com

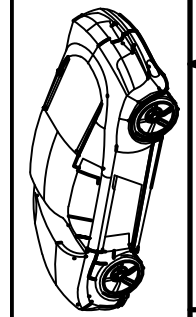

PROJECT	LOCATION	CONTRACTOR	DRAWING TITLE	DRAWN BY:	CHECKED BY:
			844	dbullard	
DATE: 2/1/2014					SCALE:
DATE:					B

FILE: 844.dwg	JOB NO.	REV.
		2
SHEET 1 OF 1	1	

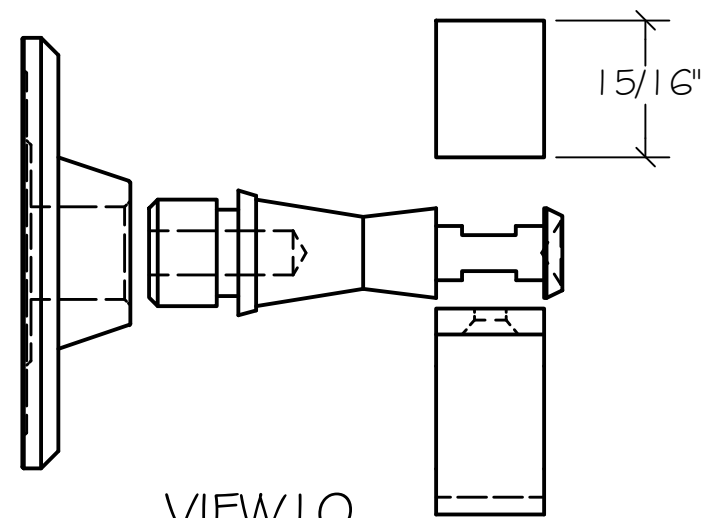

VIEW 10
SCALE: .75 : 1

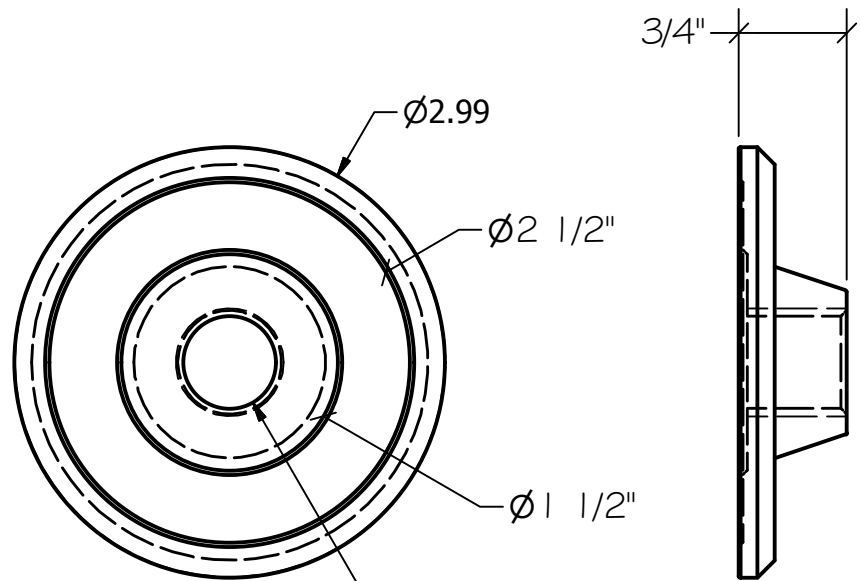
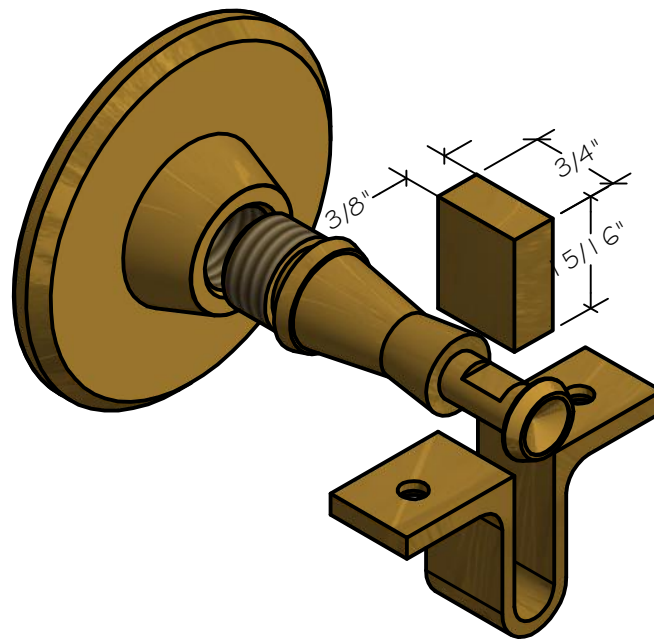

844-2
3/4-10 UNC - 2B x 3/4

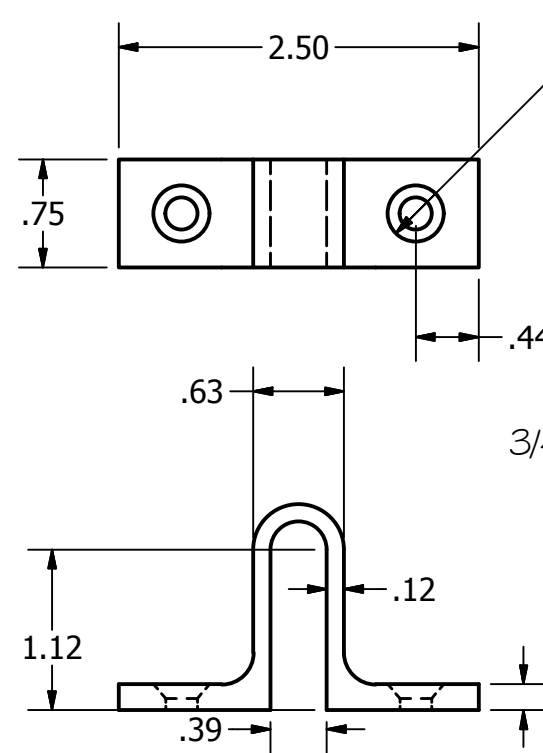

844-3
SCALE: .75: 1

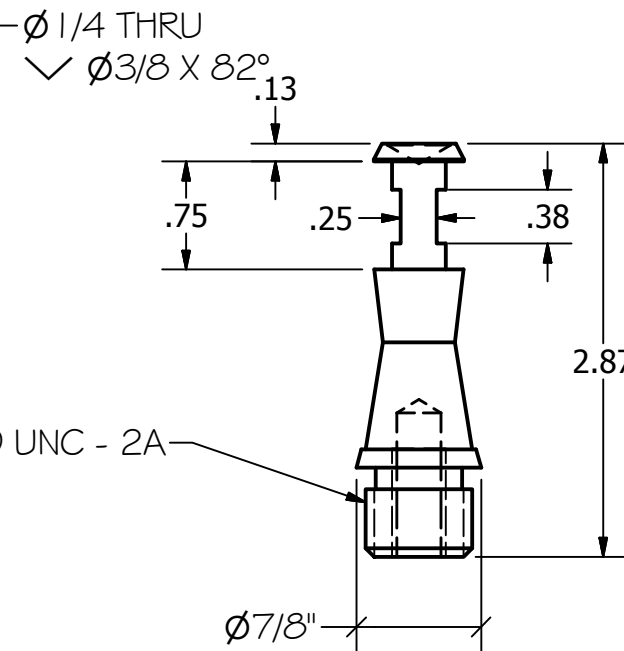

3/8-16 UNC - 2B x 3/4

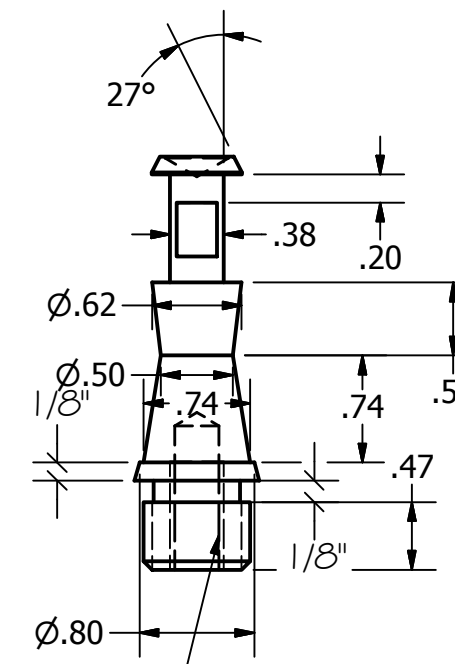

844
SCALE: .75: 1

10

9

8

7

6

5

4

3

2

1